

# Rocktech Displays Limited



Module P/N: RK040HR221

Version: 1.0

Description : 3.97inch TFT 480\*800 Pixels with  
LED backlight,All viewing angle  
300 nits brightness

TEL: 0086-755-26065260

Fax: 0086-755-26065261

E-mail: [Sales@rocktech.com.hk](mailto:Sales@rocktech.com.hk)

Web: [www.rocktech.com.hk](http://www.rocktech.com.hk)

**Revision History**

<b>Date</b>	<b>Rev.</b>	<b>Page</b>	<b>Description</b>
<b>2022-8-10</b>	<b>1.0</b>	<b>All</b>	<b>First issue</b>

# CONTENTS

- GENERAL FEATURES
- ABSOLUTE MAXIMUM RATINGS
- ELECTRICAL SPECIFICATIONS
- OPTICAL SPECIFICATIONS
- BLOCK DIAGRAM
- PIN DESCRIPTION
- TIMING CHARACTERISTICS
- OUTLINE DIMENSION
- RELIABILITY AND INSPECTION STANDARD
- PRECAUTIONS

**1. General Features**

<b>Item</b>	<b>Spec</b>	<b>Remark</b>
Display Mode	Normally Black transmissive	
Viewing Angle	FREE	IPS
Input Signals	MIPI	
Outside Dimensions	57.14 (W) x95.75(H) x2.05(D)	
Active Area	51.84mm(W)×86.40mm(H)	
Number of Pixels	480(RGB)×800	
Dot Pitch	0.108 mm(W) ×0.108mm(H)	
Pixel Arrangement	RGB Vertical stripes	
Drive IC	ST7701S	

## 2. Absolute Maximum Ratings

The following are maximum values which, if exceeded may cause operation or damage to the unit.

ITEM	Sym.	Min.	Typ.	Max.	Unit	Remark
Power for Circuit Driving	VDD	-0.3	-	4.6	V	
Backlight Forward Current	I <sub>LED</sub>	-	-	25	mA	For each LED
Storage Temperature	T <sub>ST</sub>	-30	-	70	°C	
Operating Ambient Humidity	H <sub>OP</sub>	10	-		%RH	
Operating Ambient temperature	T <sub>OP</sub>	-20	-	60	°C	

### 3. Electrical Specification

#### 3.1 Driving TFT LCD Panel

Item	Sym.	Min	Typ.	Max	Unit	Note	
Power for Circuit Driving	VDD	2.65	2.8	3.3	V		
Logic Input Voltage	Low Voltage	V <sub>IL</sub>	0	-	0.3VDD	V	
	High Voltage	V <sub>IH</sub>	0.7VDD	-	VDD	V	
Logic Output Voltage	Low Voltage	V <sub>OL</sub>	0	-	0.2VDD	V	
	High Voltage	V <sub>OH</sub>	0.8VDD	-	VDD	V	

#### 3.2 Driving Backlight

Item	Sym.	Min	Typ.	Max	Unit	Note
Backlight driving voltage	V <sub>F</sub>	-	11.8	-	V	
Backlight driving current	I <sub>F</sub>	30	40	50	mA	
Backlight Power Consumption	W <sub>BL</sub>	-	472	-	mW	
Life Time	-	-	50,000	-		Note 3

Note 1: (Unless specified, the ambient temperature Ta=25°C)

Note 2: The recommended operating conditions refer to a range in which operation of this product is guaranteed. Should this range is exceeded, the operation cannot be guaranteed even if the values may be without the absolute maximum ratings.

Note 3: If LED is driven by high current, high ambient temperature & humidity condition. The life time of LED will be reduced. Operating life means brightness goes down to 50% initial brightness. Typical operating life time is estimated data.

## 4. Optical Specifications

Optical characteristics are determined after the unit has been 'ON' and stable for approximately 30 minutes in a dark environment at 25 °C. The values specified are at an approximate distance 500mm from the LCD surface at a viewing angle of  $\Phi$  and  $\theta$  equal to 0°.

Item	Sym.	Values			Unit	Note
		Min.	Typ.	Max.		
1) Contrast Ratio	C/R	720	900	-		FIG.1
2) Module Luminance	L	250	300	-	cd/m <sup>2</sup>	FIG.1
3) Response time	Tr+Tf	-	30	-	ms	FIG.2
4) Viewing Angle	$\theta_T$	-	80	-	Degree	FIG.3
	$\theta_B$	-	80	-		
	$\theta_L$	-	80	-		
	$\theta_R$	-	80	-		
5) Chromaticity	Wx	0.230	0.270	0.310		
	Wy	0.255	0.295	0.335		
	Rx	-	-	-		
	Ry	-	-	-		
	Gx	-	-	-		
	Gy	-	-	-		
	Bx	-	-	-		
	By	-	-	-		

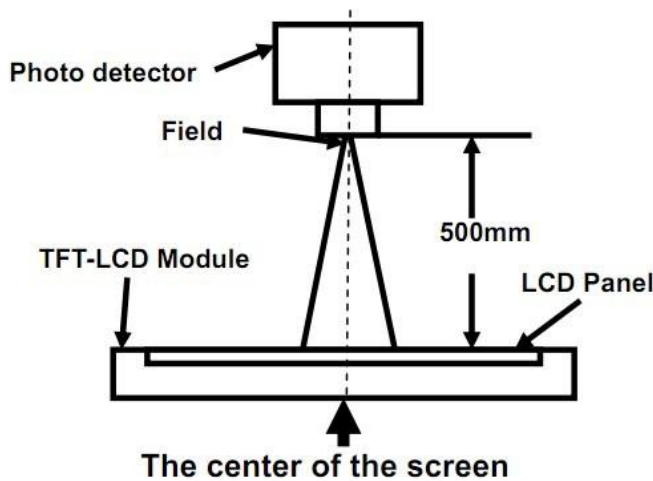
## ◆ Measurement System

Notes:

1. Contrast Ratio(CR) is defined mathematically as :  

$$\text{Contrast Ratio} = \frac{\text{Surface Luminance with all white pixels}}{\text{Surface Luminance with all black pixels}}$$
2. Surface luminance is the center point across the LCD surface 500mm from the surface with all pixels displaying white. For more information see FIG 1.
3. Response time is the time required for the display to transition from white to black (Rising Time, Tr) and from black to white (Falling Time, Tf). For additional information see FIG 2.
4. Viewing angle is the angle at which the contrast ratio is greater than 10. The angles are determined for the horizontal or x axis and the vertical or y axis with respect to the z axis which is normal to the LCD surface. For more information see FIG 3.

**FIG. 1 Optical Characteristic Measurement Equipment and Method**



Item	Photo detector	Field
Contrast Ratio	SR-3A	1°
Luminance		
Chromaticity		
Lum Uniformity		
Response Time	BM-7A	2°

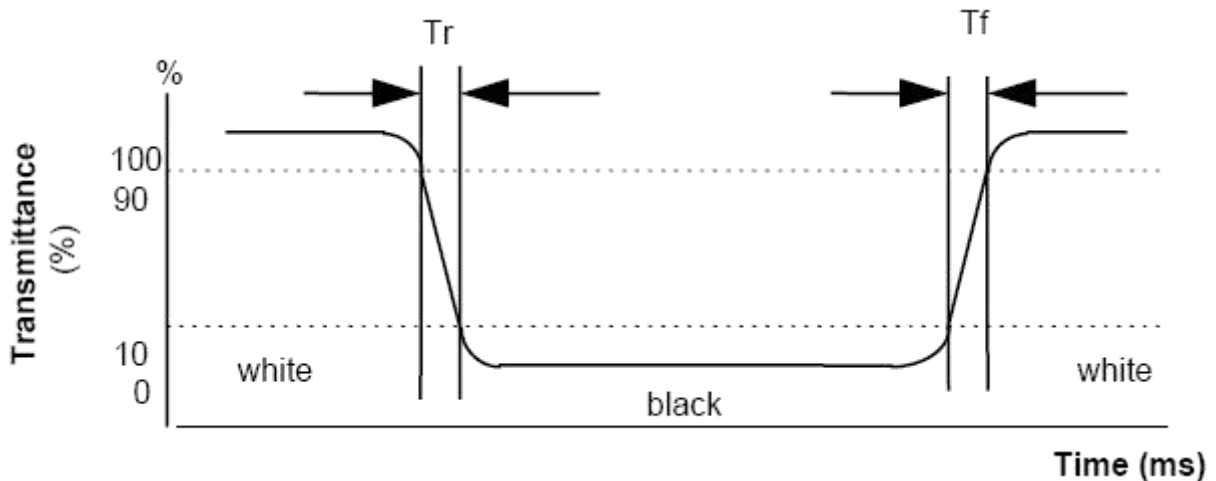


**FIG. 2 The definition of Response Time**

The response time is defined as the following figure and shall be measured by switching the input signal for “black” and “white”.

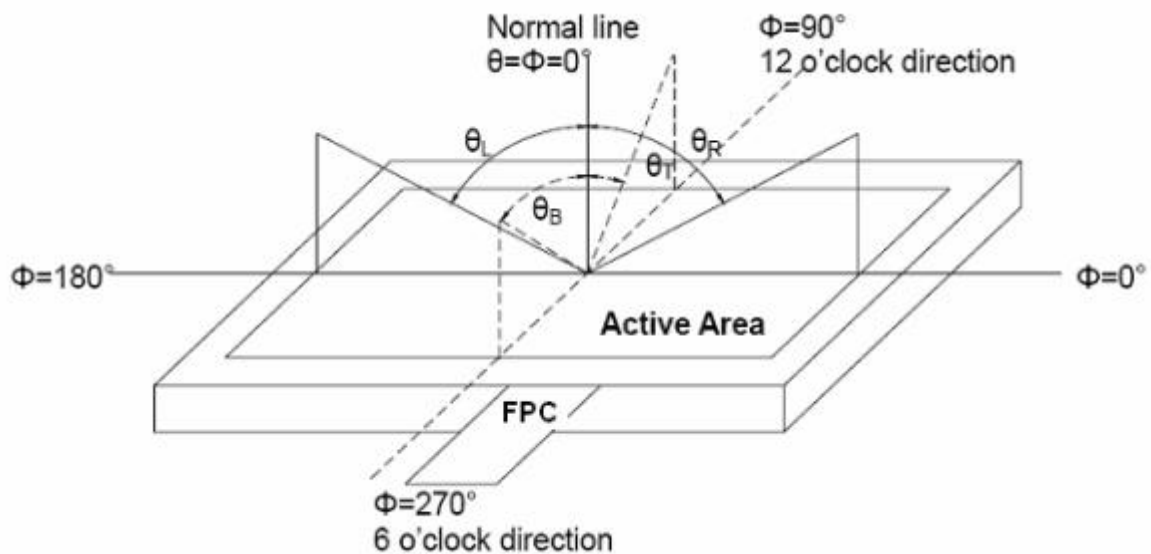
$$\text{Response Time} = \text{Rising Time}(Tr) + \text{Falling Time}(Tf)$$

- Rising Time( $Tr$ ) : Full White 90%  $\rightarrow$  Full White 10% Transmittance.
- Falling Time( $Tf$ ) : Full White 10%  $\rightarrow$  Full White 90% Transmittance.

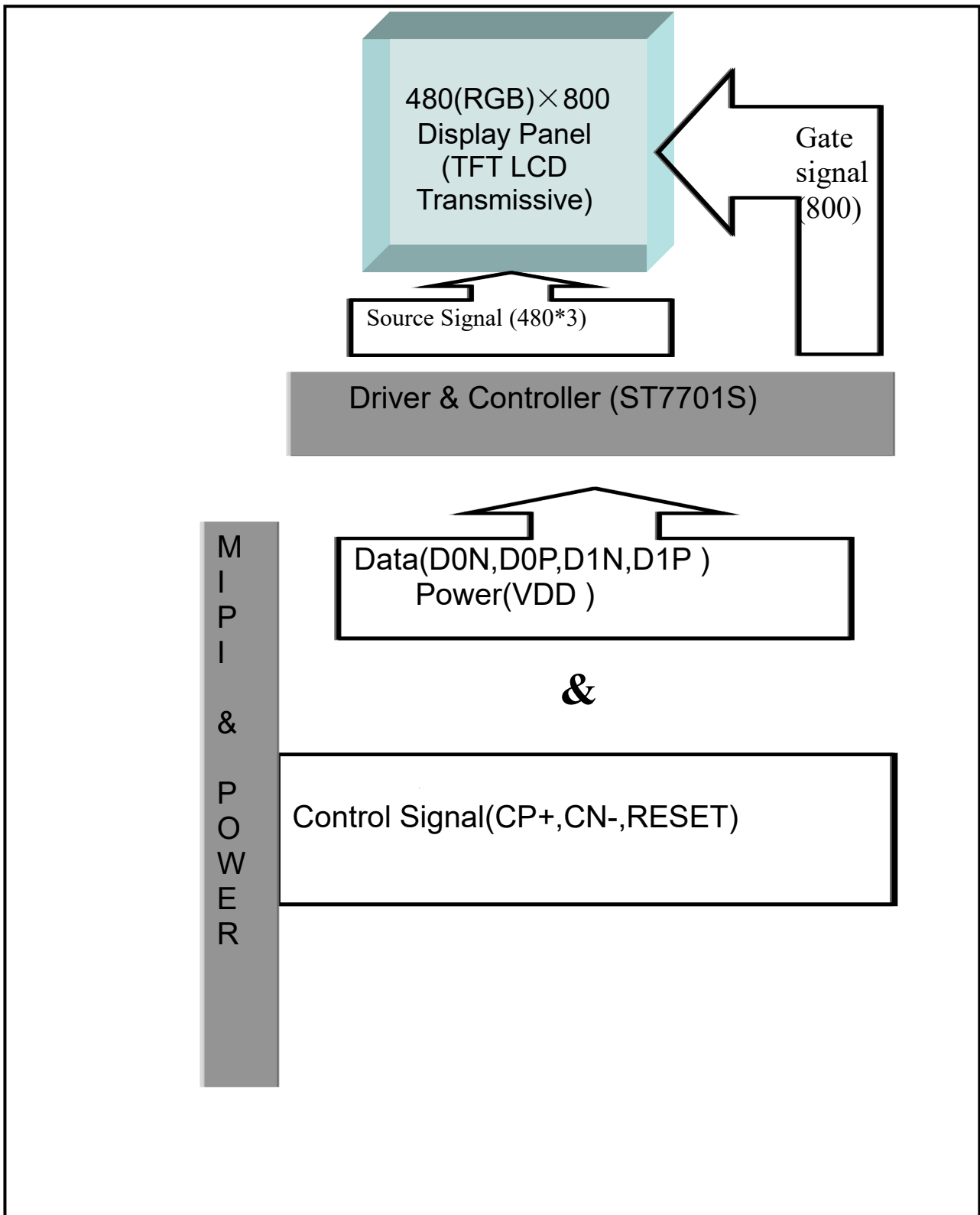


**FIG. 3 The definition of Viewing Angle**

Use Fig. 1 (Test Procedure) under Measurement System to measure the contrast from the measuring direction specified by the conditions as the following figure.



## 5. Block Diagram



## 6.Pin Description

Item	Terminal	Functions
1-2	LEDA	Backlight Anode input pin.
3-4	LEDK	Backlight Cathode input pin.
5	GND	Power ground
6-7	NC	No connection
8	GND	Power ground
9	CP+	positive polarity of low voltage differential clock signal
10	CN-	Negative polarity of low voltage differential clock signal
11	GND	Power ground
12	D1P+	Positive polarity of low voltage differential data1 signal
13	D1N-	Negative polarity of low voltage differential data1 signal
14	GND	Power ground
15	D0P+	Positive polarity of low voltage differential data0 signal
16	D0N-	Negative polarity of low voltage differential data0 signal
17	GND	Power ground
18	NC	No connection
19	RESET	The reset signal pin
20-21	VDD	Power supply 2.8V
22	NC(CTP_SCL)	No connection
23	NC(CTP_SDA)	No connection
24	NC(CTP_RST)	No connection
25	NC(CTP_INT)	No connection
26	GND	Power ground
27	VDD	Power supply 2.8V

## 7. Timing Characteristics

### 7.1 High Speed Mode Characteristics



Figure 4 DSI clock channel timing

Figure 5 Rising and falling time on clock and data channel

*VDDI=1.8, VDD=2.8, AGND=DGND=0V, Ta=25 °C*

Signal	Symbol	Parameter	MIN	MAX	Unit	Description
DSI-CLK+/-	$2xU_{INST}$	Double UI instantaneous	4	25	ns	
DSI-CLK+/-	$U_{INSTA}$ $U_{INSTB}$	UI instantaneous halves	2	12.5	ns	$UI = U_{INSTA} = U_{INSTB}$
DSI-Dn+/-	$t_{DS}$	Data to clock setup time	0.15	-	UI	
DSI-Dn+/-	$t_{DH}$	Data to clock hold time	0.15	-	UI	

Table 7 Mipi Interface- High Speed Mode Timing Characteristics

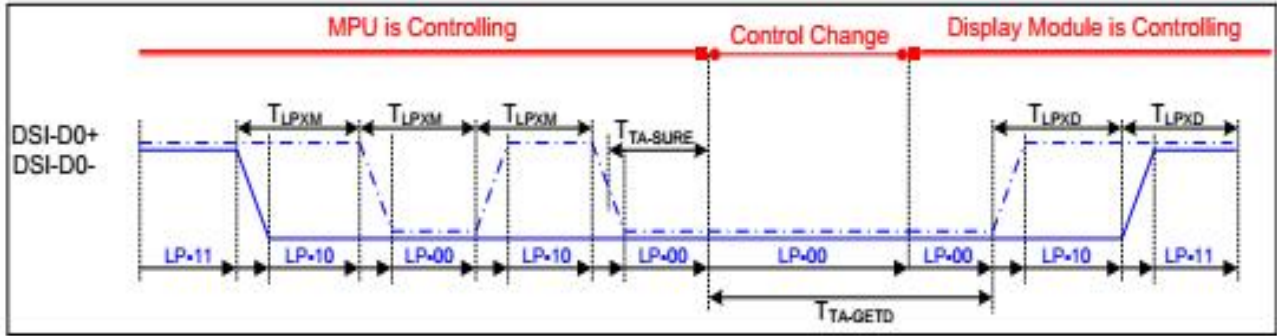


Figure 6 Bus Turnaround (BTA) from display module to MPU Timing

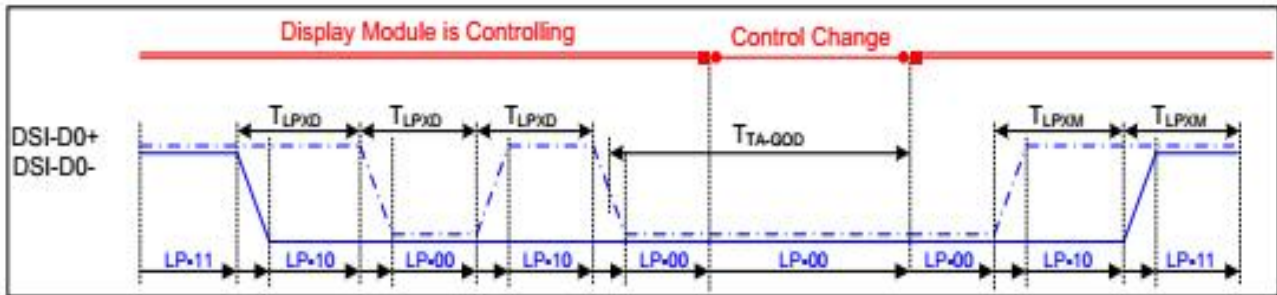


Figure 7 Bus Turnaround (BTA) from MPU to display module Timing

VDDI=1.8, VDD=2.8, AGND=DGND=0V, Ta=25 °C

Signal	Symbol	Parameter	MIN	MAX	Unit	Description
DSI-D0+/-	TLPXM	Length of LP-00, LP-01, LP-10 or LP-11 periods MPU→Display Module	50	75	ns	Input
DSI-D0+/-	TLPXD	Length of LP-00, LP-01, LP-10 or LP-11 periods MPU→Display Module	50	75	ns	Output
DSI-D0+/-	TTA-SURED	Time-out before the MPU start driving	$T_{LPXD}$	$2 \times T_{LPXD}$	ns	Output
DSI-D0+/-	TTA-GETD	Time to drive LP-00 by display module	$5 \times T_{LPXD}$		ns	Input
DSI-D0+/-	TTA-GOD	Time to drive LP-00 after turnaround request-MPU	$4 \times T_{LPXD}$		ns	Output

Table 8 Mipi Interface Low Power Mode Timing Characteristics

## 7.2 Reset Operation

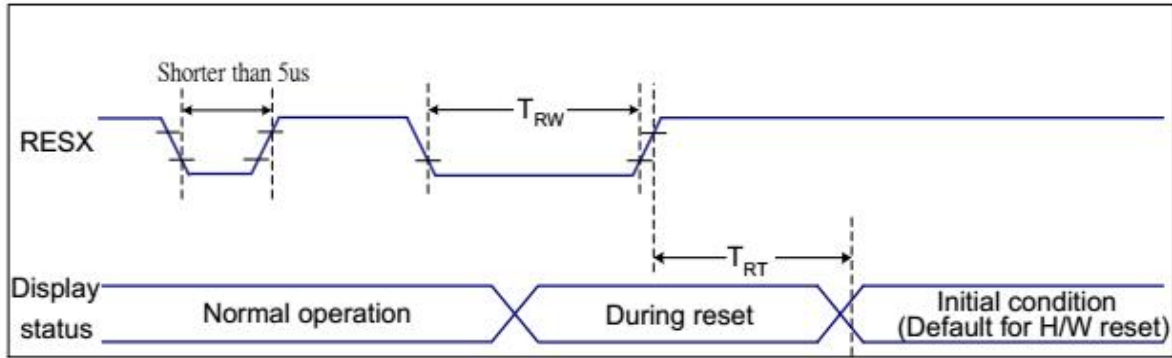


Figure 9 Reset Timing

VDDI=1.8, VDD=2.8, AGND=DGND=0V, Ta=25 °C

Related Pins	Symbol	Parameter	MIN	MAX	Unit
RESX	TRW	Reset pulse duration	10	-	us
	TRT	Reset cancel	-	5 (Note 1, 5)	ms
				120 (Note 1, 6, 7)	ms

Table 9 Reset Timing

Notes:

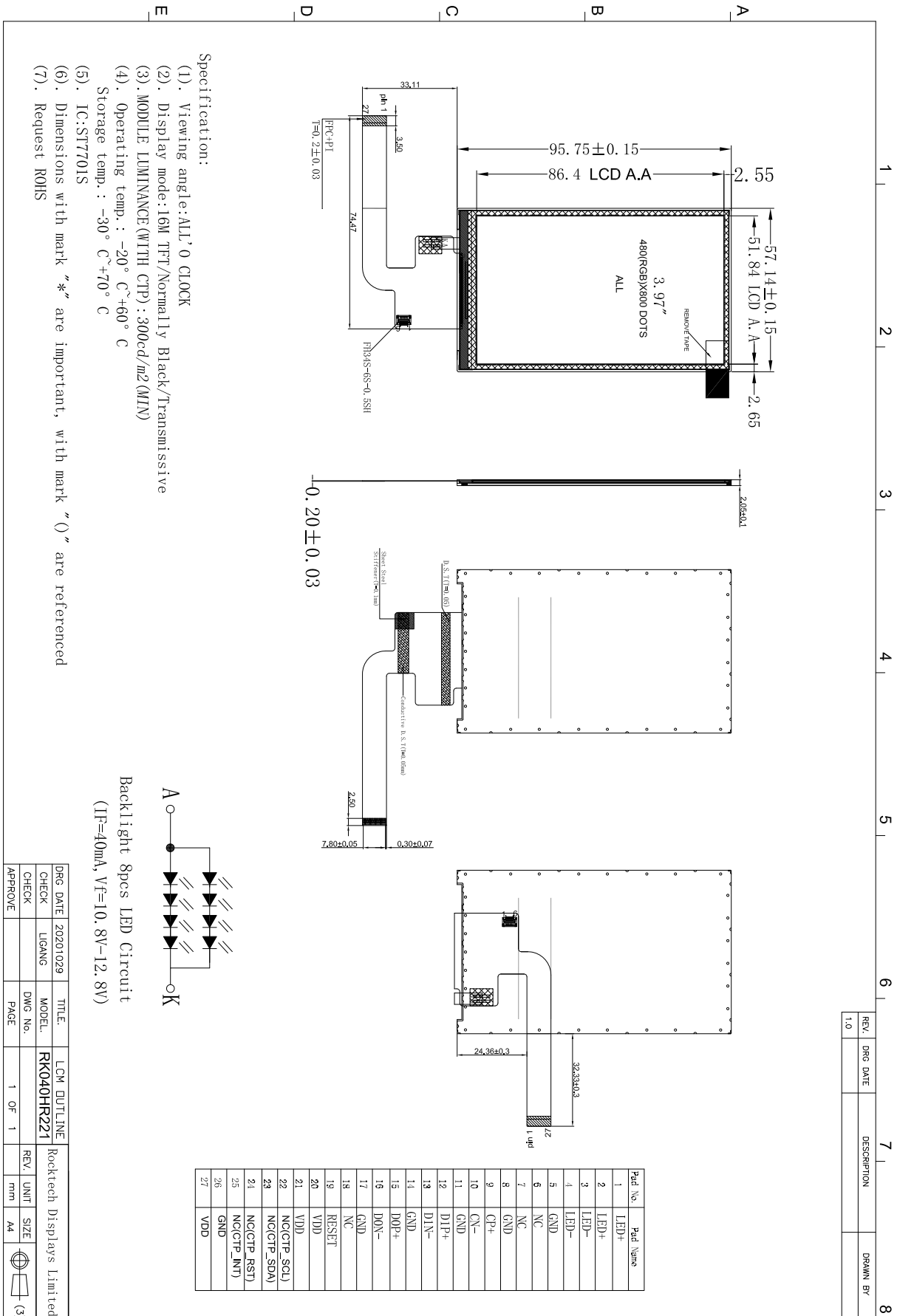
- The reset cancel includes also required time for loading ID bytes, VCOM setting and other settings from NVM (or similar device) to registers. This loading is done every time when there is HW reset cancel time (TRT) within 5 ms after a rising edge of RESX.
- Spike due to an electrostatic discharge on RESX line does not cause irregular system reset according to the table below:

RESX Pulse	Action
Shorter than 5us	Reset Rejected
Longer than 9us	Reset
Between 5us and 9us	Reset starts

- During the Resetting period, the display will be blanked (The display is entering blanking sequence, which maximum time is 120 ms, when Reset Starts in Sleep Out –mode. The display remains the blank state in Sleep In –mode.) and then return to Default condition for Hardware Reset.

- Spike Rejection also applies during a valid reset pulse as shown below:

## 8.Outline Dimension



REV.	DRG DATE	DESCRIPTION	DRAWN BY
1.0			

DRG DATE	TITLE	LCM OUTLINE
20201029		

CHECK	UIGANG	MODEL	RK040HR221

CHECK	DWG No.	REV.	UNIT	SIZE
			mm	A4

APPROVE	PAGE	1 OF 1	REV.	UNIT	SIZE
				mm	A4

## 9. Reliability and Inspection Standard

No.	Test Item	Test Conditions	Remark	
1	High Temperature	Storage	70°C, 120Hr	Note
		Operation	60°C, 120Hr	Note
2	Low Temperature	Storage	-30°C, 120Hr	Note
		Operation	-20°C, 120Hr	
3	High Temperature and High Humidity	40°C, 90%RH, 120Hr	Note	
4	Thermal Cycling Test(No operation)	-20°C for 30min, 60°C for 30 min. 100 cycles. Then test at room temperature after 1 hour	Note	
5	Vibration Test(No operation)	Frequency :10~55 HZ; Stroke :1.5 mm; Sweep:10HZ~55HZ~10HZ; 2hours for each direction of X, Y, Z(6 hours for total)		
6	Package Drop Test	Height:60 cm, 1 corner, 3 edges, 6 surfaces		
7	Electro Static Discharge	±2KV, Human Body Mode, 100pF/1500Ω		

Note:

- 1) Sample quantity for each test item is 5~10pcs.
- 2) Note 4: Before cosmetic and function test, the product must have enough recovery time, at least 2 hours at room temperature.



## 10. PRECAUTIONS FOR USING LCD MODULES

### Handling Precautions

- (1) The display panel is made of glass and polarizer. As glass is fragile, it tends to become or chipped during handling especially on the edges. Please avoid dropping or jarring. Do not subject it to a mechanical shock by dropping it or impact.
- (2) If the display panel is damaged and the liquid crystal substance leaks out, be sure not to get any in your mouth. If the substance contacts your skin or clothes, wash it off using soap and water.
- (3) Do not apply excessive force to the display surface or the adjoining areas since this may cause the color tone to vary. Do not touch the display with bare hands. This will stain the display area and degraded insulation between terminals (some cosmetics are determined to the polarizer).
- (4) The polarizer covering the display surface of the LCD module is soft and easily scratched. Handle this polarizer carefully. Do not touch, push or rub the exposed polarizers with anything harder than an HB pencil lead (glass, tweezers, etc.). Do not put or attach anything on the display area to avoid leaving marks on. Condensation on the surface and contact with terminals due to cold will damage, stain or dirty the polarizer. After products are tested at low temperature they must be warmed up in a container before coming in contact with room temperature air.
- (5) If the display surface becomes contaminated, breathe on the surface and gently wipe it with a soft dry cloth. If it is heavily contaminated, moisten cloth with one of the following solvents
  - Isopropyl alcohol
  - Ethyl alcoholDo not scrub hard to avoid damaging the display surface.
- (6) Solvents other than those above-mentioned may damage the polarizer. Especially, do not use the following.
  - Water
  - Ketone
  - Aromatic solventsWipe off saliva or water drops immediately, contact with water over a long period of time may cause deformation or color fading. Avoid contacting oil and fats.
- (7) Exercise care to minimize corrosion of the electrode. Corrosion of the electrodes is accelerated by water droplets, moisture condensation or a current flow in a high-humidity environment.
- (8) Install the LCD Module by using the mounting holes. When mounting the LCD module make sure it is free of twisting, warping and distortion. In particular, do not forcibly pull or bend the I/O cable or the backlight cable.
- (9) Do not attempt to disassemble or process the LCD module.
- (10) NC terminal should be open. Do not connect anything.
- (11) If the logic circuit power is off, do not apply the input signals.
- (12) Since LCM has been assembled and adjusted with a high degree of precision, avoid applying excessive shocks to the module or making any alterations or modifications to it.
  - Do not alter, modify or change the shape of the tab on the metal frame.
  - Do not make extra holes on the printed circuit board, modify its shape or change the positions of components to be attached.
  - Do not damage or modify the pattern writing on the printed circuit board.
  - Absolutely do not modify the zebra rubber strip (conductive rubber) or heat seal

connector.

- Except for soldering the interface, do not make any alterations or modifications with a soldering iron.
- Do not drop, bend or twist LCM.

## **Storage Precautions**

When storing the LCD modules, the following precaution is necessary.

- (1) Store them in a sealed polyethylene bag. If properly sealed, there is no need for the dessicant.
- (2) Store them in a dark place. Do not expose to sunlight or fluorescent light, keep the temperature between 0°C and 35°C.
- (3) The polarizer surface should not come in contact with any other objects. (We advise you to store them in the container in which they were shipped).

## **Others**

Liquid crystals solidify under low temperature (below the storage temperature range) leading to defective orientation or the generation of air bubbles (black or white). Air bubbles may also be generated if the module is subject to a low temperature.

If the LCD modules have been operating for a long time showing the same display patterns, the display patterns may remain on the screen as ghost images and a slight contrast irregularity may also appear. A normal operating status can be regained by suspending use for some time. It should be noted that this phenomenon does not adversely affect performance reliability.

To minimize the performance degradation of the LCD modules resulting from destruction caused by static electricity etc., exercise care to avoid holding the following sections when handling the modules.

- Exposed area of the printed circuit board.
- Terminal electrode sections.